



Antimicrobial

Institutional Commercial



800 SERIES

DETAILS

AM800STS

Antimicrobial, Extra Heavy Duty, closed front with cover for elongated bowl. Stainless steel reinforced check hinge.

AMFR800STSS

Antimicrobial, fire retardant, Extra Heavy Duty closed front with cover for elongated bowl. Stainless steel reinforced check hinge. Self sustaining ring.

Standard Features:

- Corrosion free steel hinge
- Integrally molded permanent and sanitary color keyed bumpers
- Corrosion free hardware
- Withstands cleansers, strong chemicals
- Easy clean
- Finger lift

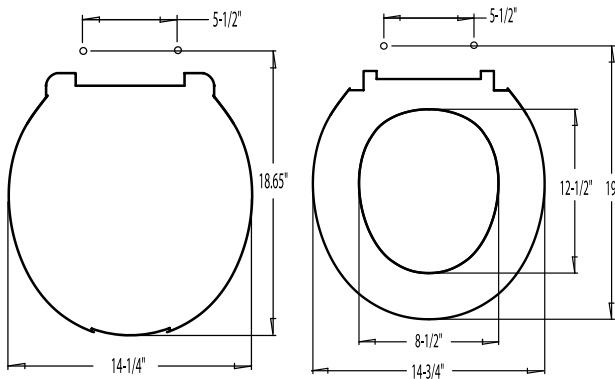

SPECIFICATIONS

Seats shall be Centoco No. _____
Seat and cover shall be injection molded of polypropylene with integrally molded permanent bumpers.

Color to be _____.